

Dimensional Summary

Welding Fittings: ANSI and NAVSEA 810-1385880D

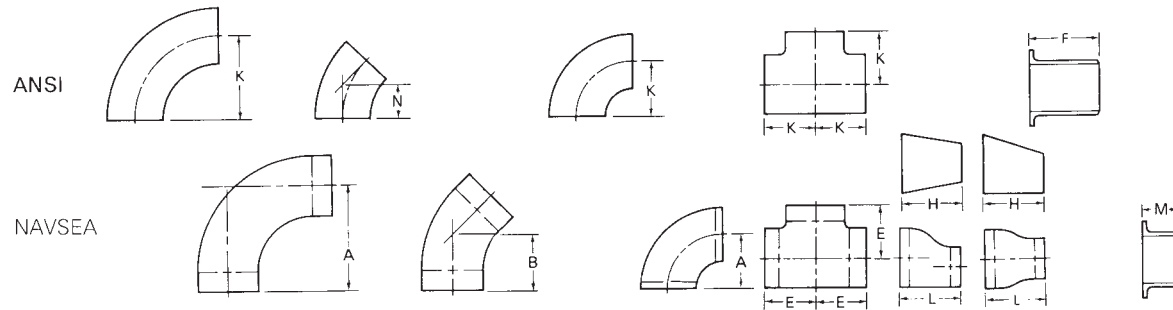

Nominal Pipe Size	Outside Diameter	B 16.9 LR 90 K	NAVSEA LR 90 A	B 16.9 LR 45 N	NAVSEA LR 45 B	B 16.28 SR 90 K	NAVSEA SR 90 A	NAVSEA Tee or Cross E,K	B 16.9 NAVSEA Reducer L,H	B 16.9 ANSI Stub End F	MSS Stub End M
1/2	.840	1 1/2		5/8				1		3	2
3/4	1.05	1 1/8		7/16				1 1/8	1 1/2	3	2
1	1.31	1 1/2	2	7/8	1 1/8	1		1 1/2	2	4	2
1	1.66	1 7/8	2 7/16	1	1 11/32	1 1/4		1 7/8	2	4	2
1 1/2	1.90	2 1/4	2 15/16	1 1/8	1 5/8	1 1/2		2 1/4	2 1/2	4	2
2	2.375	3	3 23/32	1 3/8	1 31/32	2		2 1/2	3	6	2 1/2
2 1/2	2.875	3 3/4	4 5/8	1 3/4	2 7/16	2 1/2		3	3 1/2	6	2 1/2
3	3.5	4 1/2	5 13/32	1 7/8	2 49/64	3	3 29/32	3 3/8	3 1/2	6	2 1/2
4	4.5	6	6 31/32	2 1/2	3 29/64	4	4 31/32	4 1/8	4 1/8	6	3
5	5.562	7 1/2	8 19/32	3 1/8	4 13/64	5	6 3/32	4 7/8	5	8	3
6	6.625	9	10 11/64	3 3/4	4 29/64	6	7 11/64	5 5/8	5 1/2	8	3 1/2
8	8.625	12	13 3/8	5	6 11/32	8	9 3/8	7	6	8	4
10	10.75	15	16 9/16	6 1/4	7 25/32	10	11 9/16	8 1/2	7	10	5
12	12.75	18	19 11/16	7 1/2	9 9/64	12	11 11/16	10	8	10	6
	14	21	21 1/2	8 3/4	9 1/4	14	14 11/16	11	13	12	6
	16	24	24 1/2	10	10 1/2	16	16 1/2	12	14	12	6
	18	27	27 1/2	11 1/4	11 3/4	18	18 1/2	13 1/2	15	12	6
	20	30	30 1/2	12 1/2	13	20	20 1/2	15	20	12	6
	22	33	33 1/2	13 1/2	14	22	22 1/2	16 1/2	20	12	
	24	36	36 1/2	15	15 1/2	24	24 1/2	17	20	12	6
	26	39		16		26		19 1/2	24		
	28	42		17 1/4		28		20 1/2	24		
	30	45		18 1/2	19	30		30 1/2	22		
	32	48		19 3/4		32		23 1/2	24		
	34	51		21		34		25	24		
	36	54		22 1/4	22 1/4	36	36 1/2	26 1/2	24		
	38	57		23 5/8		38		28	24		
	40	60		24 7/8		40		29 1/2	24		
	42	63		26 1/8		42			24		
	44	66		27 3/8		44			24		
	46	69		28 5/8		46			28		
	48	72		29 7/8		48			28		

Note: Dimensions for welding fittings with OD and ID tubing size diameters are identical to the fitting dimensions above. Dimensions are in inches.

*Sizes 26" through 48" are per Alaskan Standard.