

Length Dimensions for Outlets

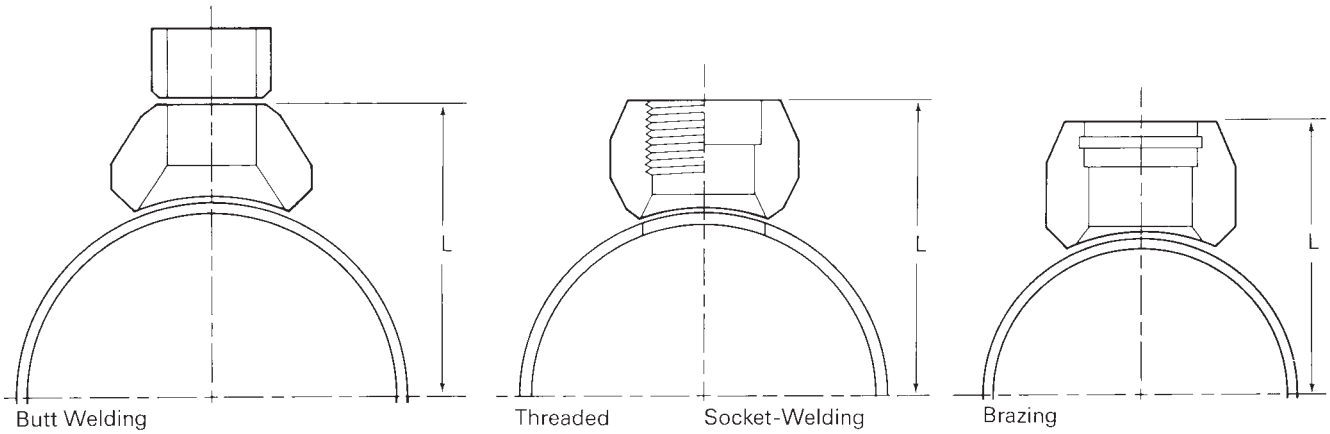

Run Nominal Pipe Size	Schedule or Weight	Outlet Nominal Pipe Size															
		1/8	1/2	3/8	1/2	3/4	1	1 1/4	1 1/2	2	2 1/2	3	3 1/2				
3/8	*	1	1														
1/2	*	1 1/16	1 1/16	1 3/16	1 1/16												
3/4	*	1 3/16	1 3/16	1 1/4	1 1/4	1 7/16											
1	*	1 5/16	1 5/16	1 3/8	1 3/8	1 1/2	1 11/16										
1 1/4	*	1 7/16	1 7/16	1 9/16	1 9/16	1 11/16	1 7/8	2 1/16									
1 1/2	*	1 9/16	1 9/16	1 11/16	1 11/16	1 13/16	2	2 3/16	2 1/4								
2	*	1 13/16	1 13/16	1 15/16	1 15/16	2 1/16	2 1/4	2 7/16	2 1/2	2 11/16							
2 1/2	*	2 1/16	2 1/16	2 3/16	2 3/16	2 5/16	2 1/2	2 11/16	2 3/4	2 15/16	3 1/16						
3	*	2 3/8	2 3/8	2 1/2	2 1/2	2 5/8	2 13/16	3	3 1/16	3 1/4	3 3/8	3 1/2					
3 1/2	*	2 5/8	2 5/8	2 3/4	2 3/4	2 7/8	3 1/16	3 1/4	3 5/16	3 1/2	3 5/8	3 3/4	3 7/8				
4	*	2 7/8	2 7/8	3	3	3 1/8	3 5/16	3 1/2	3 9/16	3 3/4	3 7/8	4	4 1/8				
5	*	3 7/16	3 7/16	3 9/16	3 9/16	3 11/16	3 7/8	4 1/16	4 1/8	4 5/16	4 7/16	4 9/16	4 11/16				
6	*	3 15/16	3 15/16	4 1/16	4 1/16	4 3/16	4 3/8	4 9/16	4 5/8	4 13/16	4 15/16	5 1/16	5 3/16				
8	*	4 15/16	4 15/16	5 1/16	5 1/16	5 3/16	5 3/8	5 9/16	5 5/8	5 13/16	5 15/16	6 1/16	6 3/16				
10	*	6	6	6 1/8	6 1/8	6 1/4	6 7/16	6 5/8	6 11/16	6 7/8	7	7 1/8	7 1/4				
12	*	7	7	7 1/8	7 1/8	7 1/4	7 7/16	7 5/8	7 11/16	7 7/8	8	8 1/8	8 1/4				
14	*	7 5/8	7 5/8	7 3/4	7 5/8	7 7/8	8 1/16	8 1/4	8 5/16	8 1/2	8 5/8	8 3/4	8 7/8				
16	*	8 5/8	8 5/8	8 3/4	8 3/4	8 7/8	9 1/16	9 1/4	9 5/16	9 1/2	9 5/8	9 3/4	9 7/8				
18	*	9 5/8	9 5/8	9 3/4	9 3/4	9 7/8	10 1/16	10 1/4	10 5/16	10 1/2	10 5/8	10 3/4	10 7/8				
20	*	10 5/8	10 5/8	10 3/4	10 3/4	10 7/8	11 1/16	11 1/4	11 5/16	11 1/2	11 5/8	11 3/4	11 7/8				
24	*	12 5/8	12 5/8	12 3/4	12 3/4	12 7/8	13 1/16	13 1/4	13 5/16	13 1/2	13 5/8	13 3/4	13 7/8				

Dimensions are in inches. Root gap is not included in the L dimensions shown.
 * Lengths shown are for schedules 5s and 10s, Regular and Extra Strong.